

09/2018

Mod: **DRINK-110S/R2**

Production code: **FSC1950S-P**



**Diamond**  
catering equipment



## FSC1950S-P Display Cooler

### Product features:

- LED illuminated canopy
- Ventilated cooling
- Internal vertical LED light
- Self-closing sliding glass doors
- 1 bottom shelf
- 4 adjustable shelves
- Adjustable feet

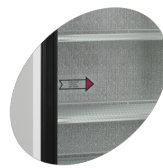

Sliding doors



Vertical internal light

### Technical data

Climate Class	4
Temperature Range, °C	2 to 10
Gross Volume, l.	857
Net. Volume, l.	700
External Dimensions, WxDxH	1110x825x2010
Internal Dimensions, WxDxH	1000x652x1533
Packing Dimensions, WxDxH	1180x910x2100
40'ft Container load, pcs.	22
Door	2 self-closing sliding glass
Shelves	5
Exterior	White
Interior	Coated steel
Castors/Feet	4 rollers and 4 adjustable feet
Lock	No
Voltage/Frequency, V/Hz.	220-240/50
Rated Input Power, W.	490
Energy Consumption. kWh/24h.	6.5
Gross Weight, kg.	198
Net. Weight, kg.	193
Noise Level, db(A)	48
Type of Cooling	Ventilated
Type of Defrost	Automatic
Type of Control	Electronic
Thermometer	Yes
Refrigerant	R290
Charge, g.	125
Internal Light	LED
Canopy light	LED

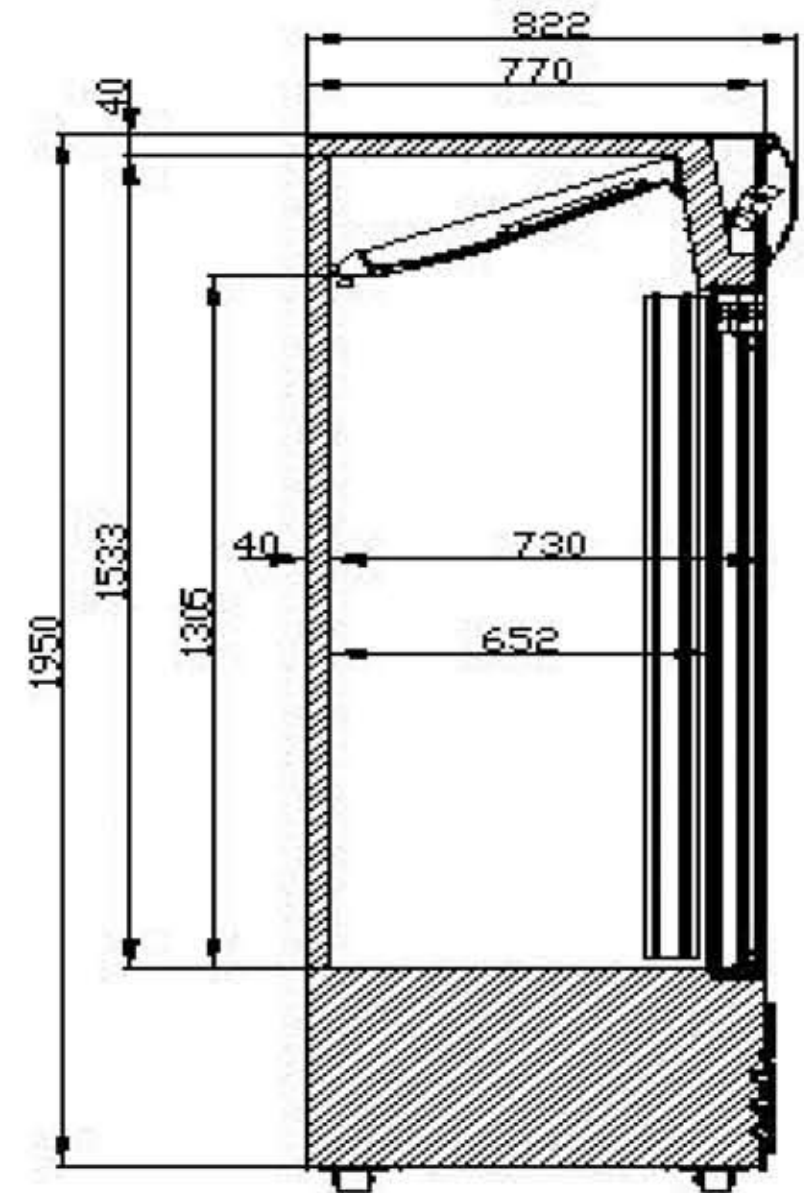
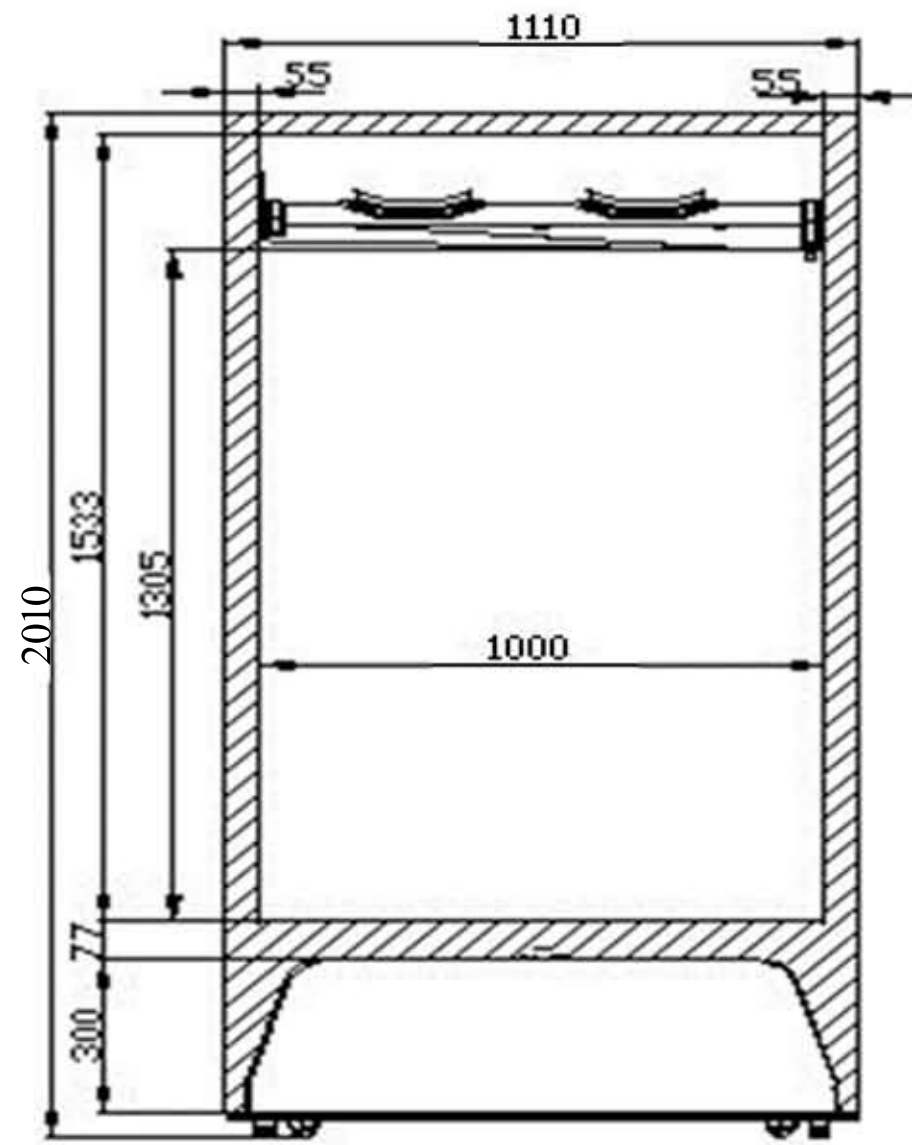
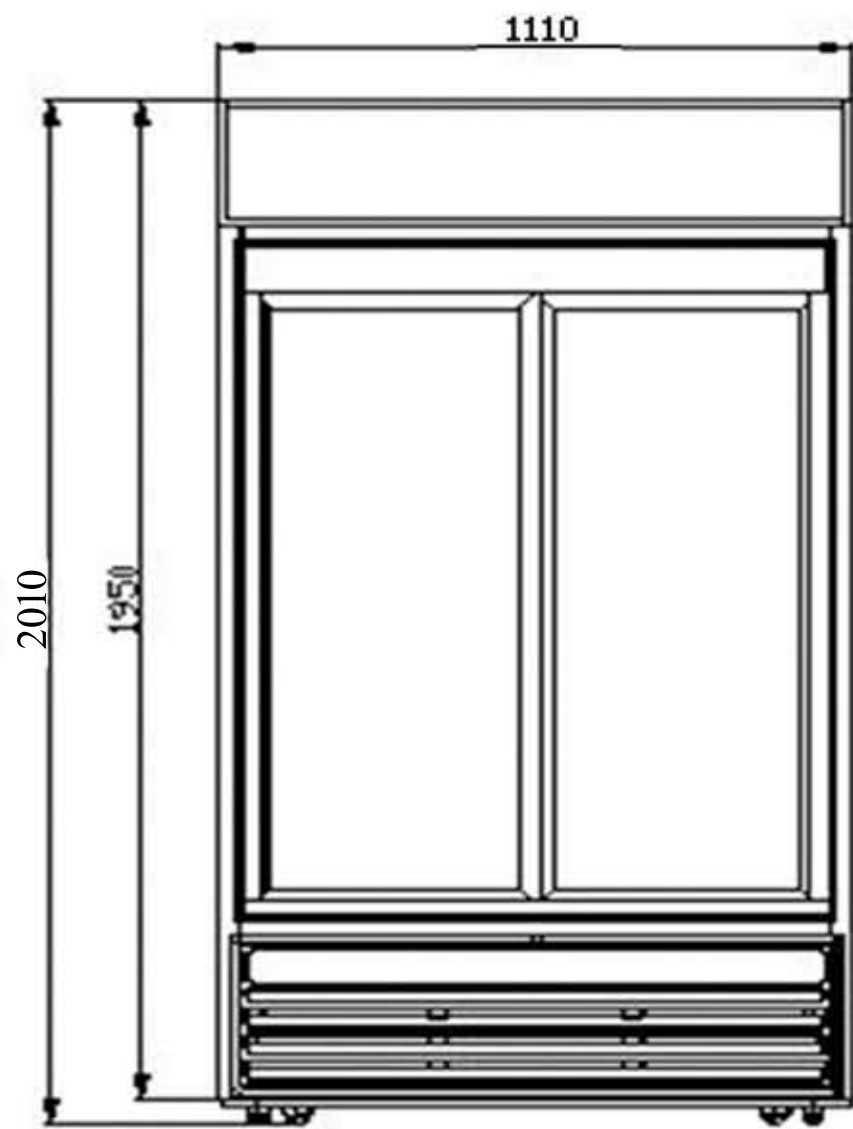

	Date: 140413
Model: FSC1950S	Rev.: 01
Dimensions	Rev. by: rfj
Drawing no.:	